



# ***SPECIALIST ROTARY***

## **SCREW COMPRESSOR CONTROLLER OPERATING MANUAL**

---

*MAM SERIES AIR SCREW CONTROLLER AND PROTECTION SYSTEMS FOR  
SPECIALIST ROTARY SR ECO LINE SERIES SCREW COMPRESSORS WITH  
MAM-6070/6080/6090 PLC SYSTEMS FOR SR-75H TO SR-175H FIXED SPEED,  
SR-10VSD TO SR-60VSD AND SR-75HVSD TO SR-175HVSD VARIABLE SPEED*



## NOTICE

- Please read instruction manual before use.
- Installation of MAM controllers should only be performed by a professional technician.
- Installation of the MAM controller needs to take into consideration heat dissipation and electromagnetic interference.
- Wiring must be installed according to regulations for high and low currents to reduce electromagnetic interference.
- Surge arrestors must be used with inductive loads, such as AC contactors, on the output control of relay.
- Inspect port connections carefully before powering on.
- In order for the unit to resist signal noise, it is imperative that the MAM controller be earthed correctly.
- The motors' rated current – MAM overload auto stop current – must be set according to the rated current indicated on motor name plate  $\times$  overload current multiplication factor of 1.2.

## FEATURES

- Multiple run modes optional.
- Colour touch screen, with control buttons.
- Supports real time power consumption and accumulative power consumption measurement and display.
- Scheduled on/off function and scheduled pressure function optional.
- High-speed and accurate frequency control for VSD models.
- Interfaces with all inverters supporting MODBUS RTU protocol.
- Phase lack, current overload, current imbalance, high voltage, low voltage and motor protection.
- High level of integration, high reliability and high efficiency.

# CONTENTS

<b>1. Basic operation .....</b>	<b>5</b>
1.1 Button explanation .....	5
1.2 Indicator explanation .....	6
1.3 Status display and operation .....	6
1.4 Run parameters .....	7
1.5 User parameters .....	9
1.6 Factory parameters .....	11
1.7 Calibration parameters .....	13
1.8 Block parameters .....	15
1.9 Hardware parameters .....	15
1.10 Maintenance parameters .....	16
1.11 Inverter set .....	17
1.12 Touch calibration .....	18
1.13 Scheduled P .....	19
1.14 Scheduled on-off .....	19
1.15 History record .....	19
1.16 Motor VSD .....	20
1.17 Fan VSD .....	23
1.18 Date .....	24
1.19 Operation authorization and passwords .....	25
<b>2. Controller Function and Technical Parameter .....</b>	<b>26</b>
2.1 Ambient temperature .....	26
2.2 Digital input & output .....	26
2.3 Analog input & output .....	26
2.4 Input voltage of phases .....	26
2.5 High voltage, low voltage protection .....	26
2.6 Controller power supply .....	26
2.7 Measurement .....	26
2.8 Phase anti-reversal protection .....	26
2.9 Motor protection .....	26
2.10 Temperature protection .....	27
2.11 Contact capacity of output relay .....	27
2.12 Current error reporting is less than 1.0% .....	27
2.13 RS485 communication port .....	27
2.14 Remote controlling the compressor .....	27

## Contents (Cont).

<b>3. Model and Specification .....</b>	<b>27</b>
3.1 Model explanation .....	27
3.2 Power specification sheet for corresponding motor .....	27
<b>4. Installation .....</b>	<b>28</b>
4.1 CT Installation .....	28
4.2 Controller installation - MAM-6070 / MAM-6080 / MAM-6090 .....	29
<b>5. Alarm functions .....</b>	<b>34</b>
5.1 Air filter alarm .....	34
5.2 Oil filter alarm .....	34
5.3 O/A separator alarm .....	34
5.4 Lubricant alarm .....	34
5.5 Grease alarm .....	34
5.6 Discharge high temperature alarm .....	34
<b>6. Controller protection .....</b>	<b>35</b>
6.1 Motor protection .....	35
6.2 Protection of discharge temperature high .....	35
6.3 Protection of air compressor (anti-reverse rotation) .....	35
6.4 Protection of air compressor against open phase (dropped phase) .....	35
6.5 Protection of air pressure high .....	35
6.6 Protection of sensor fault .....	35
<b>7. Troubleshooting .....</b>	<b>36</b>
<b>8. Block control and network communication .....</b>	<b>37</b>
8.1 Block control .....	37
8.2 Network communication .....	38
<b>9. Inverter control .....</b>	<b>38</b>
9.1 485 Communication control .....	38
<b>10. Schematic Wiring Diagram .....</b>	<b>40</b>
10.1 SR Fixed speed modules with 6070 controller .....	40
10.2 SR Fixed speed single-stage with MAM-6080 controller .....	47
10.3 SR Variable speed single-stage with MAM-6080 controller .....	48
10.4 SR Variable speed two-stage with MAM-6090 controller .....	49
<b>11. Appendix Output Mode Introduction.....</b>	<b>52</b>

# 1. Basic Operation

## 1.1 Button Explanation



**Start Button:**

Press this button to start the compressor. When compressor is set as master (No.1) in array mode, press this button to start the compressor and activate block mode function at the same time.



**Stop Button:**

Press this button to stop the compressor. When compressor is set as master (No.1) in array mode, press this button to stop compressor and block function as well.



**Set Button; Load / Unload Button:**

When the compressor is running, press this button to load or unload. When modifying data in a textbox, press this button to save data. When the cursor is at any page icon, press to execute the corresponding function.



**Return Button / Reset Button:**

When the controller is alarming in stop status, press this button for 5 seconds to reset. When modifying data, press this button to exit data setting mode. When viewing the menu, press this button to return to previous menu.



**Scroll Left Button:**

When checking data in a textbox, press this button to enter data modifying mode; data starts to blink from right to left. When modifying data in a textbox, press this button to move the cursor to the left. When modifying data in data set and display icon, press this button to modify and save the data. When cursor is on a page icon, press to move to the previous icon.



**Move Right Button / Enter Button:**

When checking data in a textbox, press this button to enter data modifying mode; data starts to blink from left to right. When modifying data in textbox, press this button to move the cursor to the right. When modifying data in data set and display icon, press this button to modify and save the data. When cursor is on a page icon, press to move to the next icon.



**Move Down Button / Decrease Button:**

When checking data, press this button to move the cursor downward to the next icon. When modifying data in a textbox, press this button to decrease the current value. When the current page is on Run Parameters, press this button to scroll to the next page.



**Move Up Button / Increasing button:**

When checking data, press this button to move the cursor downward to the previous icon. When modifying data in a textbox, press this button to increase the current data value.





textbox

data set and display icon

page icon

## 1.2 Indicator Explanation

-  **Power:**  
Indicator illuminates when the controller is powered on.
-  **Run:**  
Indicator illuminates when the motor is running.
-  **Alarm:**  
Indicator blinks when the controller alarms. Indicator illuminates when the compressor is alarming and stopped. Indicator is off after the error is cleared and reset.

## 1.3 Status Display and Operation

The display screen will appear after powering on:





After 5 seconds, the menu will appear as shown here:



## 1.4 Run Parameters

Select "RUN PARAMETER" to check the relative data and settings below:

Menu	Preset Data	Function
OIL FILTER	0020H	Record total running time of the oil filter.
O/A SEPARATOR	0020H	Record total running time of the O/A separator.
AIR FILTER	0020H	Record total running time of the air filter.
LUBE	0020H	Record total running time of lubricant.
GREASE	0020H	Record total running time of grease.
MOTOR CURRENT	A: 000.0A B: 000.0A C: 000.0A	Displays motor current.
FAN CURRENT	A: 000.0A B: 000.0A C: 000.0A	Displays fan current.
THIS Runtime	0000:00:00	Record compressor's current runtime.
THIS LOAD TIME	0000:00:00	Record compressor's current load time.
INPUT STATE	1 2 3 4 5 6 7 8 9 10  1: In accordance with No.5 digital input state; 2: In accordance with No.6 digital input state; 3: In accordance with No.7 digital input state; 4: In accordance with No.8 digital input state; 5: In accordance with No.9 digital input state; 6: In accordance with No.10 digital input state;  Red dot input state means the terminal is connected; orange dot input state means the terminal is disconnected.	
OUTPUT STATE	1 2 3 4 5 6 7 8 9 10  1: In accordance with No.17 digital output state; 2: In accordance with No.16 digital output state; 3: In accordance with No.15 digital output state; 4: In accordance with No.14 digital output state; 5: In accordance with No.13 digital output state; 6: In accordance with No.12 digital output state;  Red dot input state means the terminal is connected; orange dot input state means the terminal is disconnected.	
MOTOR RATED SPEED	0000 RPM	Display of motor RPM based on the calculation of the motor's frequency reading.
MOTOR RATED POWER	000.0 Hz	Displays the output frequency of the motor inverter.

### 1.4 Run Parameters (cont).

MOTOR OUTPUT CURRENT	000.0 A	Displays the output current of the motor inverter.
MOTOR OUTPUT VOLTAGE	000.0 V	Displays the output voltage of the motor inverter.
MOTOR OUTPUT POWER	000.0 Kw	Displays the real time output power of the motor inverter.
MOTOR THIS POWER CONSUMPTION	0000000.0Kw.H	Displays the accumulative power consumption based on the motor inverter real time output power.
MOTOR TOTAL POWER CONSUMPTION	0000000.0Kw.H	Displays the accumulative total power consumption based on the motor inverter real time output power.
MOTOR STATE DESCRIPTION	0000	Displays in the motor status area, based on the running status register data output from the motor inverter.
ERROR DESCRIPTION	0000	Displays in the controller error reports section, based on the running error register data output from the motor inverter.
WRITE FREQUENCY	000.0	Displays the motor frequency based on PID calculation.
FAN SPEED	0000 RPM	Displays fan real time speed based on the fan frequency reading.
FAN OUTPUT FREQUENCY	000.0 Hz	Displays the output frequency of the fan inverter.
FAN OUTPUT CURRENT	000.0 A	Displays the output current of the fan inverter.
FAN OUTPUT VOLTAGE	000.0 V	Displays output voltage of the fan inverter.
FAN OUTPUT POWER	000.0 Kw	Displays the real time output power based on the fan inverter.
FAN THIS POWER CONSUMPTION	0000000.00Kw.H	Displays the accumulative power consumption based on the fan inverter real time output power data.
FAN TOTAL POWER CONSUMPTION	0000000.00Kw.H	Displays the accumulative total power consumption based on the fan inverter real time output power.
FAN STATE DESCRIPTION	0000	Displays in the fan status section, based on the running state register data reading from fan the inverter.
ERROR DESCRIPTION	0000	Displays in the controller error area based on the running error register data read from fan inverter.
WRITE FREQUENCY	000.0	Displays the frequency based on the PID calculation.



## 1.5 User Parameters

User parameters store relevant data. User password is required for modification of parameters

### 1 Touch operation (highlighted in yellow):

When the cursor is here, you can revise the parameter by clicking the data box directly if the password has been verified already

If the password has not been verified yet, a password verification box will prompt you. Button operation shows as below:

- While in data checking mode, press left or right button to enter data modification mode;
- While in data checking mode, press up or down button to move the cursor to next icon;
- While in data modification mode, press up or down button to revise current data;
- While in data modification mode, press left or right button to move the cursor to next data bit.



### 2 When the cursor is on the page icon, press "S" to execute the corresponding function.

#### MAIN FUNCTIONS BELOW

Menu	Preset Data	Function
LOAD P (MPa)	00.65	1. In AUTO load mode, the compressor will load if air pressure is below this set data. 2. In STANDBY mode, the compressor will start if the pressure is below this set data.
UNLOAD P (MPa)	00.80	1. The compressor will unload automatically if the air pressure is above this set data. 2. This data should be set above LOAD P, also it should be set below UNLD P LIM.
FAN START T (°C)	0080	Fan will start if DISC T is above this set data.
FAN STOP T (°C)	0070	Fan will stop if DISC T is below this set data.
MOTOR START DELAY (s)	0008	Set the MOTOR START TIME. Record time when motor is activated, the controller will not start overload protection during this time to avoid impulse starting current stopping the motor.
FAN START DELAY (s)	0003	Set the FAN START TIME. Record time when fan is activated, the controller will not start overload protection during this time to avoid impulse starting current stopping the fan.

Menu	Preset Data	Function
STAR DELAY (s)	0006	Interval time from star start to delta run state.
LOAD DELAY (s)	0002	Unloaded in this set time after entering delta run state.
STANDBY DELAY (s)	0600	When unloaded for this time continuously, the compressor will automatically stop and enter standby.
STOP DELAY (s)	0010	For NORMAL STOP operation, the compressor will stop after it continuously unloads for this set time.
RESTART DELAY (s)	0100	Machine can start only after this set time elapses (after normal stop, standby or alarm and stop).
DRAIN OPEN TIME (s)	0002	Auto drain control, continuous drain time.
DRAIN CLOSE TIME (m)	0060	Auto drain control, continuous drain interval time.
SOFT START DELAY (s)	0006	Controller starts LOAD DELAY TIME after SOFT-START DELAY (this data is only available in SOFT START mode)
LOAD MODE	MANUAL/ AUTOMATIC	MANUAL: Only when the pressure reached UNLD P, the compressor will unload automatically. For any other case, the Load/Unload function can only be executed by pressing the Load/Unload function button. AUTOMATIC: Load/Unload functions are executed by the fluctuation of AIR P automatically.
START MODE	LOCAL/REMOTE	LOCAL: Only the button on the controller can turn on / off the machine. REMOTE: Both the button on the controller and the remote control button can turn on / off the machine. Note: When one input terminal is set as REMOTE START ENABLE, the start mode is controlled by hardware status. It is remote when terminal is closed; it is local when terminal is open.
RUN MODE	PF/MOTOR VSD/ FAN VSD/MOTOR FAN VSD/SOFT START	Choose the corresponding compressor run mode according to the customer requirement and choose the corresponding schematic diagram for reference.
COM ADD	0001	Set the communication address to COMPUTER or BLOCK mode. This address is unique for every controller in the network.
BACKLIGHT ADJUSTMENT	0001	Adjust the backlight; the higher the data, the brighter the display (from level 1 to level 4).

Menu	Preset Data	Function
COM MODE	COMPUTER/ BLOCK/DISABLE	Disable: Communication function is not activated. Computer: Compressor can communicate with computer or DCS as slave according to MODBUS-RTU. Baud rate: 9600; data format: 8N1; parity bit: even parity check. Block: Compressors can work in a network.
PRESSURE UNIT	MPa/PSI/BAR	MPa: Pressure unit displays as MPa. PSI: Pressure unit displays as PSI. BAR: Pressure unit displays as BAR.
TEMPERATURE UNIT	°C / °F	°C temperature unit displays as °C. °F temperature unit is displays as °F.
LANGUAGE	CHINESE/ENGLISH	English: displays in English Chinese: displays in Chinese
USER PASSWORD	****	Users can modify the user password by using the current user password or the factory password.

## 1.6 Factory Parameter

Factory parameters are used to store relevant data. Factory password is required for checking and modification. The modification of factory parameters are the same as customer parameters.

### MAIN FUNCTIONS BELOW

Menu	Preset Data	Function
MOTOR RATED CURRENT	MAXIMUM MOTOR OVERLOAD DATA /1.2	When the motor current is more than 1.2 times the set limit, the unit will stop on overload protection (see table2.1.1).
FAN RATED CURRENT	MAXIMUM FAN OVERLOAD DATA/1.2	When the fan motor current is more than 1.2 times the set limit, the unit will stop on overload protection.
ALARM DISCT	0105	When the discharge temperature reaches this limit, the compressor will alarm.
STOP DISC T	0110	When the discharge temperature reaches this set limit, compressor will alarm and stop.
T 2 ALARM	0105	When T2 reaches this set limit, the compressor will alarm.
T 2 STOP	0110	When T2 reaches set limit, the compressor will alarm and stop.
STOP P (MPa)	00.90	When pressure reaches this set limit, the compressor will alarm and stop.
STOP P 2 (MPa)	01.00	When P2 reaches this set limit, the compressor will alarm and stop.

Menu	Preset Data	Function
UNLD P LIM (MPa)	00.85	This data is the maximum UNLD P. The UNLD P in the customer parameter must be set no higher than this data.
CURRENT UNBALANCE	0006	When $MAX - MIN \text{ CURRENT} \geq (1 + SET \text{ DATA} * MIN \text{ CURRENT} / 10)$ , the unbalanced protection function is activated, the compressor will alarm and stop, reporting MOTOR CURR UNBAL. If the set data $\geq 15$ , the unbalanced protection will not be activated.
OPEN PHASE PROT (s)	002.0	If OPEN PHASE protection $\geq 20$ seconds, OPEN PHASE protection is not activated
FAULT RECORD RESET	****	Input "8888" and press "set" button to clear all the history fault records.
ALARM LONG STOP (h)	0000	When the controller detects oil filter / air filter / O/A separator / lubricant / grease running over the max time (if the alarm is set) the compressor will alarm and stop.
MAX Runtime (h)	0000	1. When the compressor is in a stopped state and the TOTAL Runtime is over this MAX TIME setting, the compressor will alarm and stop, reporting USER MISTAKE. 2. Set the data to '0000' to disable this function.
FACTORY PASSWORD 2		Set a FACTORY PASSWORD which can be modified.
HIGH VOLTAGE (V)	0410	When voltage is detected higher than HIGH VOLTAGE, the controller will alarm and stop. When set as 0000, HIGH VOLTAGE protection function disabled.
LOW VOLTAGE (V)	0350	When voltage is detected lower than LOW VOLTAGE, the controller will alarm and stop. When set as 0000, LOW VOLTAGE protection function disabled.
VSD COM OVERTIME (s)	002.0	Record time when the controller sent first data; if controller fails to receive the feedback from the inverter within this set time, the controller will send the command again.
VSD COM INTERRUPT (s)	0020	If the controller fails to receive feedback from the inverter for the set time, the VSD COM is interrupted.
VSD COM RESTORE	0015	After VSD COM is interrupted, and the controller receives the correct data more than the set times, VSD COM is regarded as restored.

Menu	Preset Data	Function
SCHEDULED ON/OFF	DISABLE/ENABLE	ENABLE: SCHEDULED ON/OFF is activated. DISABLE: SCHEDULED ON/OFF is deactivated.
SET P SECTION	DISABLE/ENABLE	ENABLE: S SET P SECTION is valid. DISABLE: SET P SECTION is invalid.
TOTAL RUNTIME (h)	000100.00	Total runtime regardless of loaded or unloaded running time.
TOTAL LOAD TIME (h)	000095.00	Total runtime in the loaded state.

## 1.7 Calibration Parameters

Calibration parameters are used to store relevant calibration data. Calibration password is required for checking and modification.

### MAIN FUNCTIONS BELOW

Menu	Preset Data	Function
MOTOR A COEF	1.000	Input the coefficient to calibrate current. Controller displays $\text{current} = \text{sample current} \times \text{coefficient}$ . The range of coefficient: 0.800-2.000
MOTOR B COEF	1.000	
MOTOR C COEF	1.000	
FAN A COEF	1.000	
FAN B COEF	1.000	
FAN C COEF	1.000	
T 1 COEF	1.000	Input the coefficient when calibrating discharge temperature. Controller display $\text{temperature} = \text{sample temperature} \times \text{coefficient}$ . The range of coefficient: 0.800-2.000
T 2 COEF	1.000	Note: This parameter is reserved in MAM-6080
T 3 COEF	1.000	
T 4 COEF	1.000	
T 5 COEF	1.000	
T 6 COEF	1.000	
P 1 COEF	1.000	Input the coefficient to calibrate air pressure. Controller displays $\text{pressure} = \text{sample pressure} \times \text{coefficient}$ . The range of coefficient: 0.800-2.000
P 2 COEF	1.000	Note: This parameter is reserved in MAM-6080

Menu	Preset Data	Function
P COEF	1.000	Input the coefficient to calibrate air pressure. Controller display pressure =sample pressure*coefficient. The range of coefficient: 0.800-2.000
PWM1 COEF	1.000	Note: This parameter is reserved in MAM-6080
PWM2 COEF	1.000	
T 1 ZERO	0002	Calibrate controller temperature to zero. Calibrate temperature to -20°C when controller pressure sensor terminal connects the resistance in accordance with -20°C. For the calibration of temperature, it is required to calibrate T to zero first and then calibrate the coefficient.
T 2 ZERO	0002	Note: This parameter is reserved in MAM-6080
T 3 ZERO	0002	
T 4 ZERO	0002	
T 5 ZERO	0002	
T 6 ZERO	0002	
P 1 ZERO	0002	When AIR P is below this set value, the pressure is displayed as 0.00. It is used to avoid air pressure transmitter from increasing.
P 2 ZERO	0002	When P 2 is below this set value, the pressure is displayed as 0.00. It is used to avoid pressure zero from increasing.
PWM1 ZERO	0002	(Standby)
PMW2 ZERO	0002	(Standby)
PHASE PROT (V)	000.9	If the Three-phase voltages are detected as lower than the limit set here, the controller will report PHASE WRONG. If PHASE PROT =0 second, PHASE PROT is deactivated.
OPEN PHASE PROT (V)	000.0	If the open phase voltage is detected lower than the limit set here, the controller will report PHASE WRONG. If OPEN PHASE protection =0 second, OPEN PHASE protection is disabled. Note: This parameter is reserved in MAM-6080.
MOTOR CURR RATIO	020	Motor rated current/5
FAN CURR RATIO	001	Fan rated current/2.5

## 1.8 Block Parameters

Block parameters are used to store relevant blocking data. Block password is required for checking and modification.

### MAIN FUNCTIONS BELOW:

Menu	Preset Data	Function
BLOCK NUMBER	0002	Number of air compressors in block network.
BLOCK LOAD P (MPa)	00.63	In BLOCK mode, one compressor will start or load when the master AIR P is below this set limit.
BLOCK UNLOAD P (MPa)	00.78	In BLOCK mode, one compressor will stop or unload when master AIR P is above this set limit.
BLOCK DELAY (s)	0020	In BLOCK mode, when master sends two commands continuously, second command signal delay for this set time
TURN TIME (m)	0060	When master pressure is between BLOCK LOAD P and BLOCK UNLD P, the master directs slaves to work alternatively after working over this set time limit.
BLOCK MODE	PF-PF VSD-PF VSD-VSD	PF-PF: PF compressor and PF compressor work in block mode. VSD-PF: VSD compressor and PF compressor work in block mode. VSD-VSD: VSD compressor and VSD compressor work in block mode.

## 1.9 Hardware Parameters

Hardware parameters are used to set the function from terminals 5-10.

### MAIN FUNCTIONS BELOW:

Menu	Preset Data	Function
10 TERMINAL	EMERGENCY	No Function / Emergency / Remote On / Remote Off / Remote Inching / Keep Remote / Lack Water (N.C.) / Remote Load / Remote Start Enable / Remote Load/Unld / Tank High T (N.C.) / Coil High T (N.C.) / Bearing High T (N.C.) / Elec Fault (N.C.) / Motor OVLD (N.C.) / Fan OVLD (N.C.) / Oil Block (N.C.) / Oil Block (N.O.) / O/A Block (N.C.) / O/A Block (N.O.) / Air Filter Block (N.C.) / Air Filter Block (N.O.) / Air Fault (N.C.) / Dryer Fault (N.C.) / Motor INV Fault (N.O.) / Motor INV Fault (N.C.) / Fan INV Fault(N.O.) / Fan INV Fault (N.C).. Note: User can set different digital input functions.
9 TERMINAL	LACK WATER	
8 TERMINAL	OIL FILTER	
7 TERMINAL	O/A SEPARATOR	
6 TERMINAL	AIR FILTER	
5 TERMINAL	REMOTE ON/OFF	

## 1.10 Maintenance Parameters

Maintenance parameters are used to store maintenance data. Maintenance password is required for checking and modification.

### MAIN FUNCTIONS BELOW:

Menu	Preset Data	Function
OIL FILTER RUNTIME (h)	0000	Records total runtime of the oil filter. If changing the oil filter, the data should be reset manually.
O/A SEPARATOR RUNTIME (h)	0000	Records total runtime of O/A separator. If changing O/A separator, the data should be reset manually.
AIR FILTER RUNTIME (h)	0000	Records total runtime of the air filter. If changing air filter, the data should be reset manually.
LUBRICANT RUNTIME (h)	0000	Records total runtime of lubricant. If changing lubricant, the data should be reset manually.
GREASE RUNTIME (h)	0000	Records total runtime of grease. If changing grease, the data should be reset manually.
OIL FILTER MAX RUNTIME (h)	2000	1. Alarm sounds when total runtime of the oil filter is above the set data limit. 2. Set this data to "0000", alarm function for oil filter runtime is deactivated.
O/A SEPARATOR MAX RUNTIME (h)	2000	1. Alarm sounds when total runtime of O/A separator is above the set data limit. 2. Set this data to "0000", alarm function for O/A separator runtime is deactivated.
AIR FILTER MAX RUNTIME (h)	2000	1. Alarm sounds when total runtime of the air filter is above the set data limit. 2. Set this data to "0000", alarm function for air filter runtime is deactivated
LUBRICANT MAX RUNTIME (h)	2000	1. Alarm sounds when total runtime of lubricant is above the set data limit. 2. Set this data to "0000", alarm function for lubricant runtime is deactivated.
GREASE MAX RUNTIME (h)	2000	1. Alarm sounds when total runtime of grease is above the set data limit. 2. Set this data to "0", alarm function for grease runtime is deactivated.



## 1.11 Inverter Set

Inverter set is used to set inverter data. Inverter password is required for check and modification.

### MAIN FUNCTIONS BELOW.

(The following chart is an example of Schneider inverter ATV61, ATV71)

Menu	Preset Data	Function
INVERTER NAME	0ATV61	Set inverter name.
RUN (w) ADD1	2135	Corresponding address 1 of inverter start command.
RUN VALUE	0001	This data is inverter start data (please refer to communication chapter in inverter manual for different inverter).
RUN (w) ADD2	2135	Corresponding address 2 of inverter start command.
RUN VALUE	0001	This data is inverter start data (please refer to communication chapter in inverter manual for different inverter).
STOP (w) ADD	2135	Corresponding address of inverter stop command.
RUN VALUE	0001	This data is inverter start data (please refer to communication chapter in inverter manual for different inverter).
RESET (w) ADD	2135	Corresponding address of inverter reset command.
RUN VALUE	0001	This data is inverter start data (please refer to communication chapter in inverter manual for different inverter).
FREQ (w) ADD	2136	Corresponding register address of inverter running frequency source.
FREQ (r) =	REC*0001÷0001	The REC value is frequency value with one decimal. Use formula to transfer to corresponding value based on different inverter and send it to inverter. Example: 50Hz running frequency, REC value: 500. For inverter with write frequency of 2 decimals, formula: REC**0001÷0010. For inverter with write frequency of 1 decimal, formula: REC**0001÷0001. For the inverter whose max output frequency is corresponding with 10000, the formula: REC*0020÷0001.
STATE (r) ADD	2135	Read inverter running status address.
RUN S =	R AND 0001=0001	Check if inverter has run the formula (please refer to communication chapter in inverter manual).

Menu	Preset Data	Function
COM FORM	8N1-N	Set the data format of controller and inverter communication. This set should be consistent with inverter communication format. 8N1-N: 1start bit, 8 data bits, 1 stop bit, no parity bit. 8N1-E: 1start bit, 8 data bits, 1 stop bit, even parity bit. 8N1-O: 1start bit, 8 data bits, 1 stop bit, odd parity bit. 8N2-N: 1start bit, 8 data bits, 2 stop bit, no parity bit. Note: Communicate with inverter, the baud rate is fixed: 9600.
FREQ (r) ADD	0C82	Read inverter frequency address (refer to inverter manual).
FREQ (r) =	REC*0001÷0001	Calculate inverter frequency formula. Controller will carry the frequency to one decimal.
VOLT (r) ADD	0C88	Read inverter voltage address.
VOLT (r) =	REC*0001÷0001	Calculate inverter voltage formula. Controller will carry the voltage to one decimal.
CURR (r) ADD	0C84	Read inverter current address.
CURR (r) =	REC*0001÷0001	Calculate current formula. Controller will transfer the current to one decimal.
POWE (r) ADD	0C8B	Read inverter power address.
ERR S =	R AND 0000≠0000	Inverter formula error reporter.
EMERGENCY ADD	2135	Corresponding address of inverter emergency stop command.
RUN VALUE	0001	This data is inverter startup data (please refer to communication chapter in inverter manual for different inverter).

## 1.12 Touch Calibration

Touch calibration is used to adjust touch screen accuracy. Touch calibration password is required for adjustment. After entering touch calibration menu, use your fingertip or a pen to click A, B, C, D in sequence. Press "S" button to restart and save the modification. If the user wants to calibrate again, press reset button and repeat the steps.

### 1.13 Scheduled P

Scheduled P is used to set scheduled pressure. Scheduled P password is required for checking and modification.

**MAIN FUNCTIONS BELOW:**

Menu	Preset Data	Function
LOAD P (MPa)	00.65	During P START TIME and P STOP TIME, the compressor will load if AIR P is below this set limit.
UNLOAD P (MPa)	00.80	During P START TIME and P STOP TIME, the compressor will unload if AIR P is above this set limit.
SCHEDULED DESCEND P (MPa)		During P START TIME and P STOP TIME, in VSD mode, when AIR P is detected as higher than the set DESCEND P, the DESCEND F works this function is only available in MOTOR VSD or MOTOR/FAN VSD mode).
SCHEDULED VSD P (MPa)	00.70	During P START TIME and P STOP TIME, set AIR P in VSD mode to keep running stable. When pressure fluctuates around this limit, the controller will adjust the operating frequency of inverter to keep pressure constant this function is only available in MOTOR VSD or MOTOR/FAN VSD mode).
P START TIME	00:00	Set this data to activate P SECTION SEL function. Set this data to "0" to deactivate function.
P STOP TIME	00:00	Set this data to activate P SECTION SEL function. Set this data to "0" to deactivate function.

### 1.14 Scheduled On-Off

Scheduled On-Off is used to set a one week schedule of on-off time. Four periods can be set in one day. Scheduled On-Off password is required for checking and modification.

**MAIN FUNCTIONS BELOW.**

When set to 00:00, the corresponding function is deactivated.

### 1.15 History Record

Record history faults for user to find causes and solutions. 100 faults are stored.

## 1.16 Motor VSD

Motor VSD is used to set Motor VSD data and limits. Motor VSD password is required for checking and modification.

### MAIN FUNCTIONS BELOW

Menu	Preset Data	Function
VSD P (MPa)	00.70	Set AIR P in VSD mode to keep running at constant pressure. When pressure fluctuates from this set limit, the controller will adjust operating frequency of the inverter to maintain pressure close to set limit this data is only available in MOTOR VSD or MOTOR/FAN VSD mode).
MOTOR UP SPEED	1000	Restrict PID calculations in the event the frequency increases too quickly which results in motor speeding up too fast.
MOTOR DN SPEED	1000	Restrict PID calculations in the event the frequency decreases too quickly which results in motor slowing down too fast.
MOTOR RATED POWER (kW)	022.0	Set MOTOR RATED POWER in order to calculate actual power in VSD mode this data is only available in MOTOR VSD or MOTOR/FAN VSD mode).
MOTOR RATED SPEED (RPM)	1500	Set MOTOR RATED SPEED at 50Hz in order to calculate the actual speed in VSD mode this data is only available in MOTOR VSD or MOTOR/FAN VSD mode).
MOTOR INT INITIAL	0020	When detected AIR P < (PID TARGET P - INTEGRAL SCALE) or Detected AIR P > (PID TARGET P + INTEGRAL SCALE) Integral calculation is based on this data.
MOTOR INT SCALE (MPa)	00.20	(PID TARGET P - INTEGRAL SCALE) < detected AIR P < (PID TARGET P + INTEGRAL SCALE), INTEGRAL GAIN works.
MOTOR PROP GAIN	0050	Track speed of PID TARGET P, the higher the limit, the faster the track; the lower the limit, the slower the track.
MOTOR INT GAIN	0060	Track the speed of PID TARGET P and STEADY STATE ERROR; the higher the limit, the faster the track and fewer STEADY-STATE ERRORS, the smaller the data, the slower the track and more frequent STEADY-STATE ERRORS
MOTOR DIFF GAIN	0000	Track the hysteresis system (such as temperature); it is not used very often and normally set as "0000".
MOTOR MAX FREQ (Hz)	180.0Hz	The maximum operating frequency in loaded state.

Menu	Preset Data	Function
MOTOR MIN FREQ (Hz)	040.0Hz	In the process of adjustment, the minimum operating frequency when pressure is above the LOAD P pressure and still has not reached the UNLD P.
MOTOR UNLD FREQ (Hz)	0035.0Hz	Permitted operating frequency in UNLD MODE.
MOTOR INVERTER ADD	0001	Set the MOTOR VSD ADD and keep it consistent with VSD COM ADD.
MOTOR PID CYCLE (s)	000.8s	Set the PID calculation interval time to adjust motor speed.
MOTOR INVERTER MODEL	ATV61	Controller can store at most 10 different inverter communication addresses (inverters should support MODBUS RTU protocol for communication).
MOTOR STOP MODE	SLOW/FREE	<p>1. INVERTER START MODE to COM ON-OFF.                      SLOW: When controller receives stop command, INLET VALVE terminals will open. Controller sends stop command to inverter to slowly stop inverter.                      FREE: When controller receives stop command, INLET VALVE terminals will open. Controller sends write frequency through RS485. Controller frequency will decrease and send stop command to inverter 1S before stop delay countdown has completed.</p> <p>2. INVERTER START MODE to TERMINAL ON-OFF:                      SLOW: When compressor receives a stop command, INLET VALVE terminals will open and MOTOR INVERTER RUN terminal will open. The compressor will stop according to the STOP DELAY setting.                      FREE: When compressor receives stop command, INLET VALVE will open. MOTOR INVERTER RUN terminal will remain closed to control inverter frequency reduction and it will open 1s before STOP DELAY completes.</p>
INVERTER START MODE	COM ON-OFF/ TERMINAL ON-OFF	<p>COM ON-OFF: Start or stop inverter through RS485 TERMINAL. ON-OFF: Start or stop inverter through digital input.                      Note:                      1. Controller settings should be in accordance with INVERTER START MODE.                      2. When controller is set to PF/VF mode, terminal 12 functions as inverter control terminal, so only COM ON-OFF is available to control inverter.</p>

Menu	Preset Data	Function
INVERTER START NO.	0006	Maximum allowable time the controller sends start command to the inverter with no response.
INVERTER STOP NO.	0006	Maximum allowable time the controller sends stop command to the inverter with no response.
VSD MOTOR POWER CONSUMPTION (KwH)	0000000.0	Set the accumulative motor VSD running power consumption.
MOTOR INVERTER DELAY (s)	1.0	Press start button; motor sends start command to inverter after this set time.
CONSTANT POWER PRESSURE 1 (MPa)	0.60	In constant power running mode, when pressure is above the limit set here, max. output frequency is set as CONSTANT POWER FREQUENCY 1.
CONSTANT POWER PRESSURE 2 (MPa)	0.70	In constant power running mode, when pressure is above the limit set here, max. output frequency is set as CONSTANT POWER FREQUENCY 2.
CONSTANT POWER PRESSURE 3 (MPa)	0.80	In constant power running mode, when pressure is above the limit set here, max. output frequency is set as CONSTANT POWER FREQUENCY 3.
CONSTANT POWER PRESSURE 4 (MPa)	0.90	In constant power running mode, when pressure is above the limit set here, max. output frequency is set as CONSTANT POWER FREQUENCY 4.
CONSTANT POWER PRESSURE 5 (MPa)	1.00	In constant power running mode, when pressure is above the limit set here, max. output frequency is set as CONSTANT POWER FREQUENCY 5.
CONSTANT POWER PRESSURE 6 (MPa)	1.10	In constant power running mode, when pressure is above the limit set here, max. output frequency is set as CONSTANT POWER FREQUENCY 6.
CONSTANT POWER PRESSURE 7 (MPa)	1.20	In constant power running mode, when pressure is above the limit set here, max. output frequency is set as CONSTANT POWER FREQUENCY 7.
CONSTANT POWER FREQUENCY 1 (Hz)	180.0	See Note1
CONSTANT POWER FREQUENCY 2 (Hz)	160.0	
CONSTANT POWER FREQUENCY 3 (Hz)	140.0	
CONSTANT POWER FREQUENCY 4 (Hz)	120.0	

CONSTANT POWER FREQUENCY 5 (Hz)	100.0	See Note 1
CONSTANT POWER FREQUENCY 6 (Hz)	80.0	
CONSTANT POWER FREQUENCY 7 (Hz)	60.0	

Note 1: In constant power running mode:

CONSTANT POWER PRESSURE 1 <= CONSTANT POWER PRESSURE 2 <= CONSTANT POWER PRESSURE 3 <= CONSTANT POWER PRESSURE 4 <= CONSTANT POWER PRESSURE 5 <= CONSTANT POWER PRESSURE 6 <= CONSTANT POWER PRESSURE 7

Note 2:

CONSTANT POWER FREQUENCY 1 >= CONSTANT POWER FREQUENCY 2 >= CONSTANT POWER FREQUENCY 3 >= CONSTANT POWER FREQUENCY 4 >= CONSTANT POWER FREQUENCY 5 >= CONSTANT POWER FREQUENCY 6 >= CONSTANT POWER FREQUENCY 7

Note 3:

Suppose M > N, when CONSTANT POWER PRESSURE N is set to 00.00, CONSTANT POWER PRESSURE M and CONSTANT POWER FREQUENCY M, the setting will be invalid.

Note 4:

When constant power function is not required, set CONSTANT POWER PRESSURE to 00.00MPa.

## 1.17 Fan VSD

Fan VSD is used to set Fan VSD operating parameters. Fan VSD password is required for checking and modification.

### MAIN FUNCTIONS BELOW

Menu	Preset Data	Function
FAN VSD T	0078	In VSD mode, set DISC T to keep running constantly. When DISC T fluctuates around this limit, the controller will adjust operating frequency of the fan inverter to maintain DISC T close to this limit setting this setting is only available in FAN VSD or MOTOR/FAN VSD mode).
MAX VSD T	0085	When DISC T is above or equal to this set limit, fan inverter output frequency changes to FAN MAX FREQ this data is only available in FAN VSD or MOTOR/FAN VSD mode).
FAN UP SPEED	1000	Restrict PID calculations should the frequency increase too quickly which results in the fan speeding up too quickly.
FAN DN SPEED	1000	Restrict PID calculations should the frequency decrease too quickly which results in the fan slowing down too quickly.

Menu	Preset Data	Function
VSD FAN START T	0070	VSD fan will start if DISC T is above this set limit this data is only available in FAN VSD or MOTOR/FAN VSD mode.
VSD FAN STOP T	0065	VSD fan will stop if DISC T is below this set limit this data is only available in FAN VSD or MOTOR/FAN VSD mode.
FAN INT INITIAL	0020	When detected $DISC T < (PID TARGET T - INTEGRAL SCALE)$ or Detected $DISC T > (PID TARGET T + INTEGRAL SCALE)$ Integral calculation is based on this data.
FAN INT SCALE	0005	$(PID TARGET T - INTEGRAL SCALE) < detected DISC T < (PID TARGET T + INTEGRAL SCALE)$ , INTEGRAL GAIN works. Beyond this range, INT INITIAL works.
FAN PROP GAIN	0100	Track speed of PID TARGET T, the higher the limit, the faster the track and the less stable the limit; the lower the limit the slower the track and the slower the adjustment.
FAN INT GAIN	0020	Track the speed of PID TARGET T and steady state error, the higher the limit, the faster the track and less steady-state errors; the lower the limit, the slower the track and increased steady-state errors.
FAN DIFF GAIN	0000	Normally set as "0000", this function is not activated.
FAN MAX FREQ (Hz)	050.0 Hz	In the process of adjustment, the max operating frequency when temperature is over the VSD working temperature.
FAN MIN FREQ (Hz)	010.0 Hz	In the process of adjustment, the minimum operating frequency when temperature is below the VSD work temperature.
FAN UNLOAD FREQ (Hz)		
FAN INVERTER ADD	2	Set the FAN VSD ADD and keep it consistent with VSD COM ADD.
FAN PID CYCLE (s)	001.0	Set the PID calculation interval time to adjust fan speed.

### 1.18 Date

Check and set time and date.



## 1.19 Operation Authorization and Passwords

Controller provides multiple passwords and access management. According to different levels of passwords, the controller provides different levels of operating authorization, details as follows:

### 1.19.1 CUSTOMER PASSWORD: FACTORY SETTINGS:

Permissions: Allows modification of all CUSTOMER PARAMETER.

### 1.19.2 FACTORY PASSWORD: FIXED:

Permissions: Allows modification of all CUSTOMER PARAMETER.

Permissions: Allows modification of all BASIC PARAMETER, MOTOR VSD PARAMETER, FAN VSD PARAMETER in FACTORY PARAMETER

### 1.19.3 CALIBRATE PASSWORD: FIXED:

Permissions: Allows modification of all CALIBRATE PARAMETER settings.

### 1.19.4 BLOCK PASSWORD:

Permissions: Allows modification of all BLOCK PARAMETER settings.

### 1.19.5 HARDWARE CONFIG PASSWORD: FIXED:

Permissions: Allows modification of all HARDWARE CONFIG settings.

### 1.19.6 MAINTENANCE PARAMETER PASSWORD

Permissions: Allows modification of all MAINTENANCE PARAMETER settings.

### 1.19.7 INVERTER SET PASSWORD

Permissions: Allows modification of all INVERTER SET settings.

### 1.19.8 TOUCH CALIBRATION PASSWORD

Permissions: Allows modification of TOUCH ACCURACY.

### 1.19.9 SCHEDULED P PASSWORD

Permissions: Allows modification to all SCHEDULED P PARAMETER SETTINGS.

### 1.19.10 SCHEDULED ON/OFF PASSWORD

Permissions: Allows modification to all SCHEDULED ON-OFF PARAMETER settings.

### 1.19.11 MOTOR VSD PASSWORD: FIXED:

Permissions: Allows modification of all MOTOR VSD PARAMETER settings.

### 1.19.12 FAN VSD PASSWORD: FIXED:

Permissions: Allows modification of all FAN VSD PARAMETER settings.

## 2. Controller Function and Technical Parameter

### 2.1 Ambient temperature

-20°C+60°C, Humidity, ≤98%.

### 2.2 Digital input & output

6 points of digital input (function optional); 6 points of digital relay output

### 2.3 Analog input & output

1 point of Pt100 temperature input. 2 groups of three phases current input (CT provided)

### 2.4 Input voltage of phases

380V / 220V.

### 2.5 High voltage, low voltage protection

### 2.6 Controller power supply

AC16-28V, 15VA

### 2.7 Measurement

2.7.1 DISC T: - 50 - 350°C, Accuracy:±1°C.

2.7.2 Running time: 0 - 999999 hours.

2.7.3 Current: 0 - 999.9A.

2.7.4 Pressure: 0 - 1.60MPa. Accuracy - 0.01MPa.

### 2.8 Phase anti-reversal protection

When compressor stops and detects a phase reversal, it will alarm; response time ≤ 1s.

### 2.9 Motor protection

This controller provides open phase, unbalance and overload protection of motor supply and also provides overload protection to the fan motor.

2.9.1. Open phase protection: When any phase opens circuit the motor will be shut off; the response time equals the set time. This function is not activated when OPEN PHASE PROTECTION time is set over 20s.

2.9.2. Unbalance protection: When MAX-MIN current  $\geq$  SET DATA \*MIN current/10. Response time is 5s.

2.9.3. Protection features of overload (time unit: second), please see the following table 2.9.3.1 for your reference. Multiple = Iactual/Iset, response time is shown in the following table (table 2.9.3.1) according to overload multiples from 1.2 times and 3.0 times.

Time parameter Iactual/Iset	≥1.2	≥1.3	≥1.5	≥1.6	≥2.0	≥3.0
Response time (s)	60	48	24	8	5	1

Table 2.9.3.1 - Curve table for protection of motor

### 2.10 Temperature protection

When the actual temperature measured is higher than temperature set limit. Response time  $\leq 2s$ .

### 2.11 Contact capacity of output relay

250V, 5A. Contactor expected life: 500 000 activations.

### 2.12 Current error reporting is less than 1.0%

### 2.13 RS485 communication port

1 output port is for block mode or computer communication. The other is for inverter communication, like reading inverter run parameters, controlling inverter on-off or adjusting inverter frequency.

### 2.14 Remote controlling the compressor

When set as REMOTE, the user can remotely control the compressor.

## 3. Model and Specification

### 3.1 Model explanation

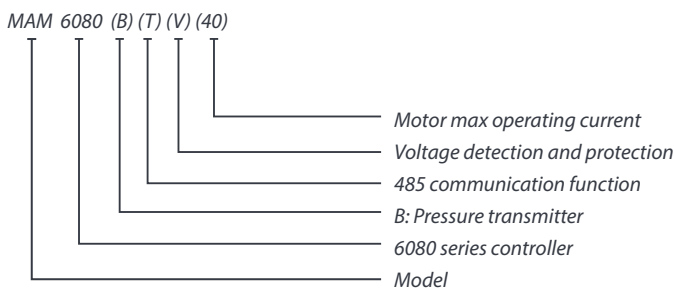

### 3.2 Power specification sheet for corresponding motor specification

Specification	Current range (A)	Corresponding main motor power (Kw)	Remark	Description
MAM-6080 (20)	8 - 20	Below 11		Fan has three levels of current, such as 0.2-2.5A, 1-5A and 4-10A, determined by current of motor.
MAM-6080 (40)	16 - 40	11-18.5		
MAM-6080 (100)	100	22-45		
MAM-6080 (200)	200	55-90		
MAM-6080 (400)	400	110		
MAM-6080 (600/5)	600/5	200-250	With CT	

Table 3.2.1 Power specification sheet for corresponding motor.

## 4. Installation

### 4.1 CT Installation

The CT must be installed where the current of motor power cables can be measured; thus the controller can be set according to specification on the motor data plate. Detailed dimensions are shown below:

#### 4.1.1 Structural dimension of CT1 ( $\phi 36$ hole)

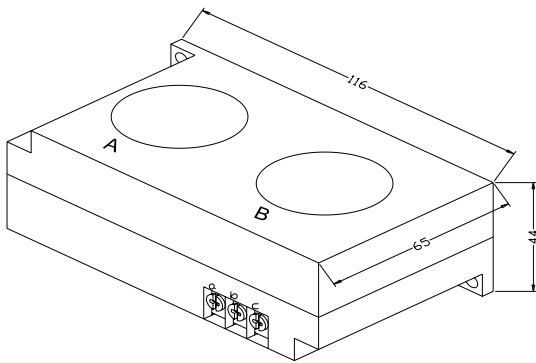

#### 4.1.2 Installation dimension of CT1

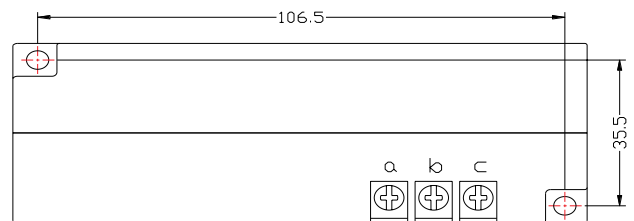

#### 4.1.3 Structural dimension of CT2 ( $\phi 10$ hole)

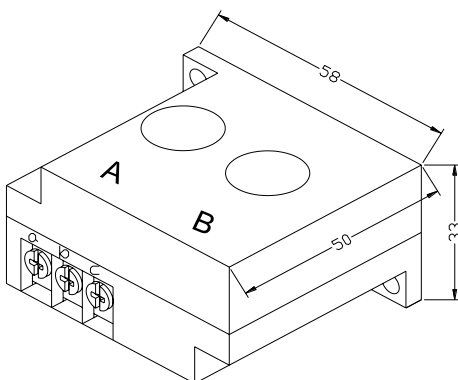

#### 4.1.4 Installation dimension of CT2

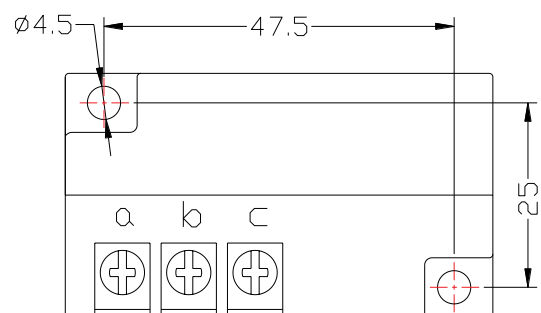

## Installation (Cont).

### 4.2 Controller Installation - MAM-6070 / MAM-6080 / MAM-6090

#### 4.2.1 Controller dimensions - MAM-6070

When installing the controller, room should be left around the controller for wiring. Specific dimensions shown below:

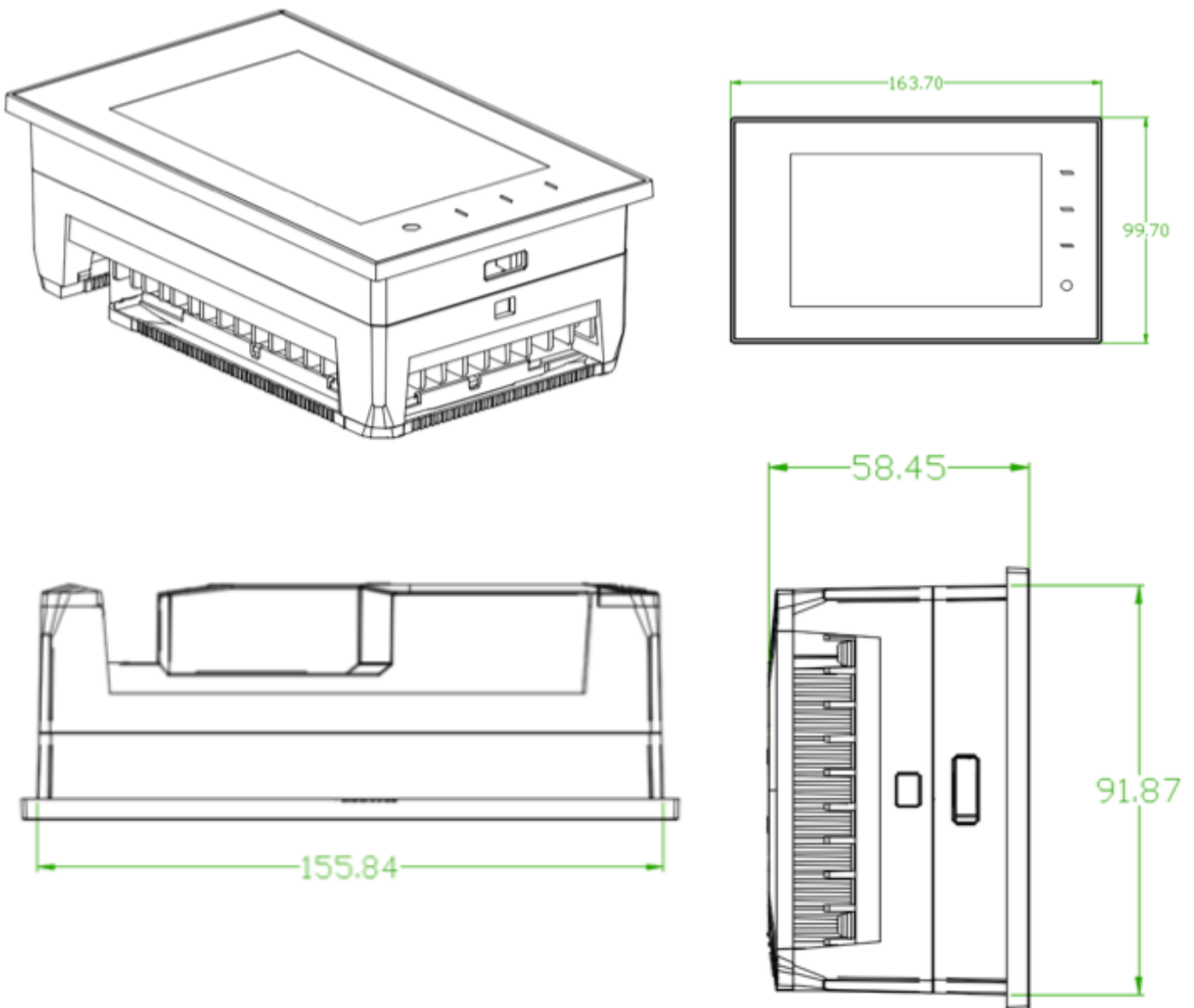

## Installation (Cont).

### 4.2.2 Hole size - MAM-6070

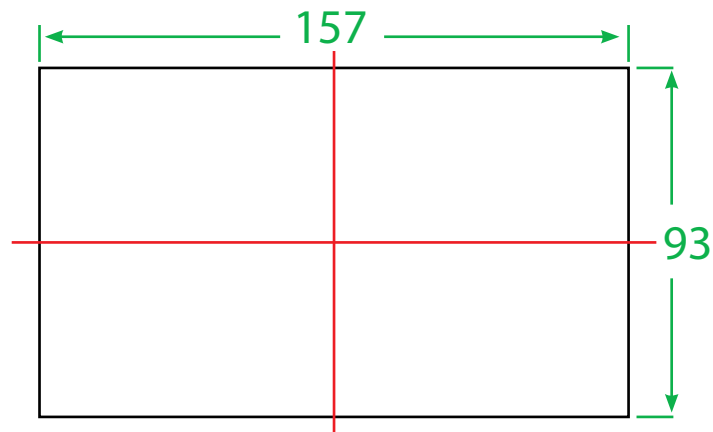

### 4.3.1 Controller dimensions - MAM-6080

When installing the controller, room should be left around the controller for wiring. Specific dimensions shown below:

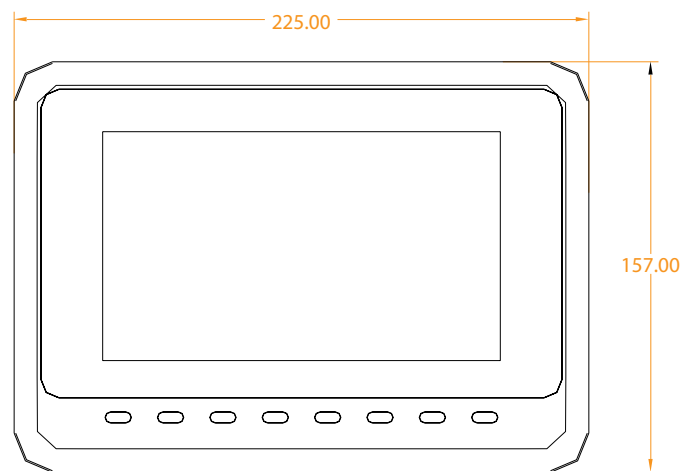
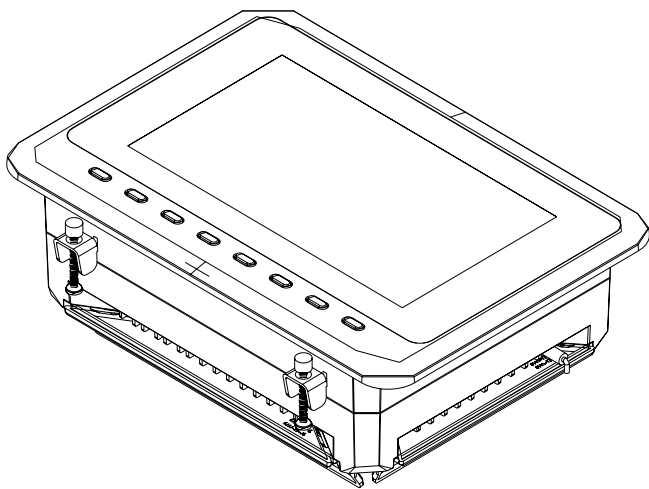

## Installation (Cont).

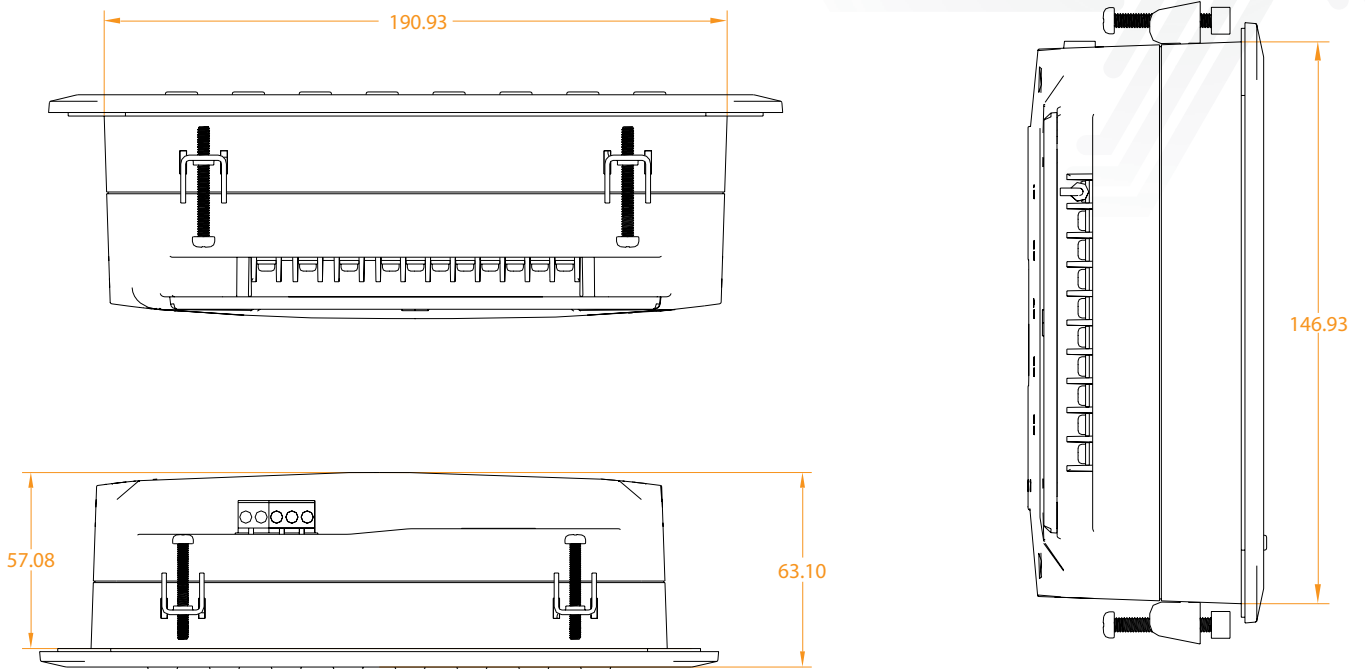

### 4.3.2 Hole size - MAM-6080

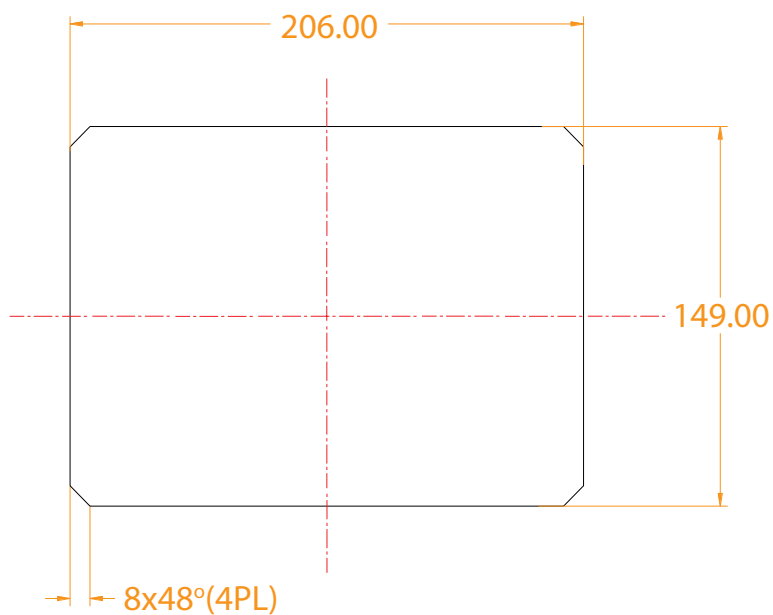

## Installation (Cont).

### 4.4.1 Controller dimensions - MAM-6090

When installing the controller, room should be left around the controller for wiring. Specific dimensions shown below:

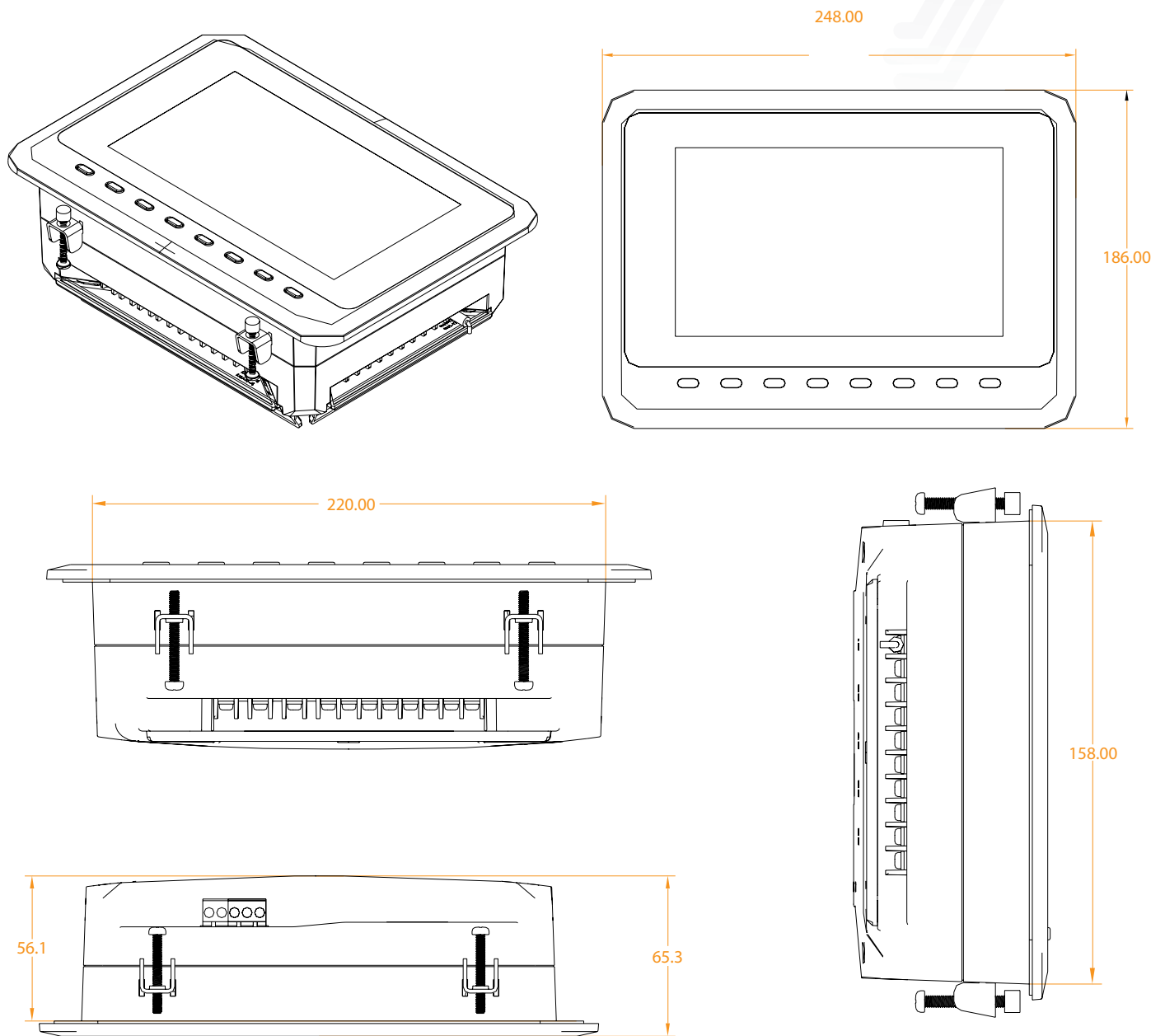



4.4.2 Hole size - MAM-6090

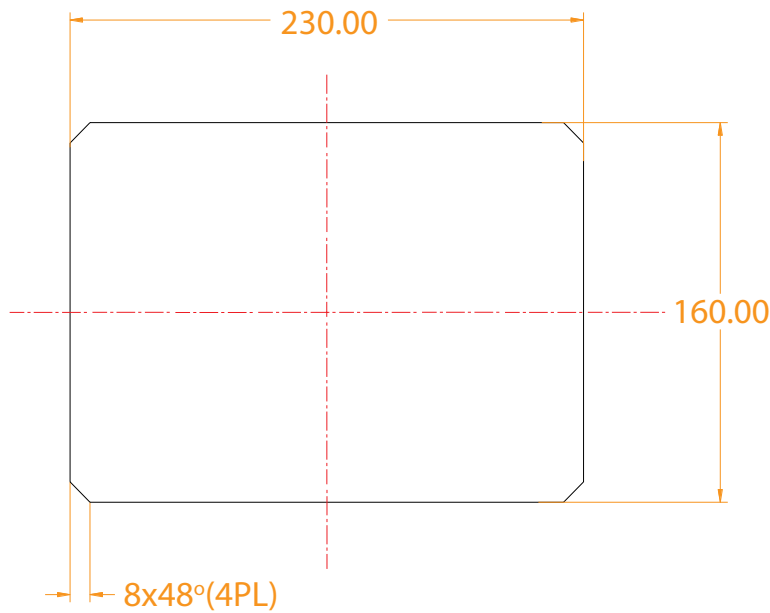

**! NOTE**

Although the rear of the controller cabinet is 190.93mm, the cut-out hole size should be at least 206mm. After connecting the cables in the rear of the controller cabinet, there will be about 10-15mm more space required. You can save the step of detaching cables when installing the controller.

## 5. Alarm Functions

### 5.1 Air Filter Alarm

1. **Air filter blockage check:**  
In HARDWARE CONFIG, there is an air check function setting in the digital input terminal. The monitor displays AIR BLOCK by checking that the pressure differential switch is closed.
2. **Air filter runtime alarm:**  
The text displays AIR TIME END when set life time of the air filter is reached.

### 5.2 Oil Filter Alarm

1. **Oil filter blockage check:**  
In HARDWARE CONFIG, there is an oil pressure check function setting in the digital input terminal. The monitor displays OIL BLOCK by checking that the pressure differential switch is closed.
2. **Oil filter runtime alarm:**  
The text displays OIL TIME END when set life time of the oil filter is reached.

### 5.3 O/A Separator Alarm

1. **O/A separator blockage check:**  
In HARDWARE CONFIG, there is O/A check function setting in the digital input terminal. The monitor displays O/A BLOCK by checking that the pressure differential switch is closed.
2. **O/A filter runtime alarm:**  
The text displays O/A TIME END when set life time of the oil filter is reached.

### 5.4 Lubricant Alarm

The screen displays LUBE TIME END when set life time of the lubricant is reached.

### 5.5 Grease Alarm

The screen displays GREASE TIME END when set life time of the grease is reached.

### 5.6 Discharge High Temperature Alarm

The screen displays DISC T HIGH when DISC T is higher than the ALARM DISC T setting in FACTORY PARAMETER.

## 6. Controller Protection

### 6.1 Motor Protection

MAM-6080 compressor controller provides overload, open phase, unbalance, high voltage, and low voltage protection to the motor and overload protection to the fan motor.

Electronic Failure	Failure Display	Reason
Overload	Display "MOTOR/FAN CURR OVLD"	Overload, bearing wear or other mechanical failure
Open phase	Display "MOTOR CUR OPEN PHASE"	Power supply, contactor and open phase of motor supply
Current Unbalance	Display "MOTOR CURR UNBAL"	Poor contact of contactor, internal open circuit of the supply
High Voltage	Display "HIGH VOLTAGE"	Motor voltage high
Low Voltage	Display "LOW VOLTAGE"	Motor voltage low

### 6.2 Protection of Discharge Temperature High

When DISC T is above the STOP DISC T, the controller will alarm and stop the machine. THIS FAULT displays DISC T HIGH.

### 6.3 Protection of Air Compressor (anti-reverse rotation)

When the compressor is in a stopped state and the three input phase sequence is not in order, THIS FAULT displays PHASE WRONG1, the controller will not start the motor. Change the position of any two phase power lines and check the rotation of motor.

### 6.4 Protection of Air compressor Against Open Phase (dropped phase)

When the compressor is in a stopped state and an open phase is detected, THIS FAULT displays PHASE WRONG2, and the controller will not start the compressor. Check the three phase inputs.

### 6.5 Protection of Air Pressure High

When the AIR P is above the MAX LIM P, the controller will alarm and stop the machine. THIS FAULT displays HIGH P.

### 6.6 Protection of Sensor Fault

When the pressure sensor or temperature sensor is disconnected, the controller will alarm and stop the machine. THIS FAULT displays \*\*SENSOR FAULT.

## 7. Troubleshooting

FAILURE	REASON	SOLUTION
High discharge temperature	Bad ventilation conditions, oil shortage, etc.	Check the ventilation conditions and lubricant levels, etc.
Temperature sensor failure	Cable broken or PT100 failure	Check the wiring and PT100
High Pressure	Pressure too high or pressure sensor failure	Check the pressure and the pressure sensor
Pressure sensor failure	Cable broken, sensor failure or cables connected incorrectly	Check the wiring and pressure transmitter
Open phase	Open phase or contactor failure	Check the power supply and contactors
Overload	Voltage too low, tubes blocked, bearing wear or other mechanical failure. Incorrect data settings, etc.	Check the set data limits, voltage, bearings, tubes and other mechanical systems
Unbalance	Current imbalance, contactor failure or the internal open circuit of motor	Check the power, contactor and the motor
Incorrect phase sequence	Phase sequence reversal or open phase	Check the wiring
Motor overload during start	Master start time is set to less than the star delta delay time	Reset the master start time longer than star delay + 2 seconds
Main Contactor engages frequently	The emergency stop button wiring is loose or the controller is reset by interference	Check if the coil of the contactor is connected with and RC scrubber or not
Inverter communication fault	Wrong setting of relevant parameters of the controller and inverter. Communication cable loose	Check the set data limits. Check the cable connections

## 8. Block Control and Network Communication

### 8.1 Block Control

MAM-6080 control systems can work in block mode with MAM series compressors (with communication function). A maximum total of 16 compressors can work together in a network. Block mode can be set as VSD-VSD,PF-PF or VSD-PF. The cable connection for block mode control is as below - 1,2 terminals (RS485 terminal) are used for block mode.

In BLOCK PARAMETER SET menu, set as VSD-VSD or PF-PF. The master selects compressors to work according to the TOTAL RUNTIME and balances operating hours among the machines. Compressors with shorter running time are chosen to start and compressors with longer running time are chosen to stop with priority.

In BLOCK PARAMETER SET menu, set as VSD-PF, the master activates first, the other compressors work according to the TOTAL RUNTIME. Compressors with shorter running times are chosen to start and compressors with longer running time are chosen to stop with priority.

Picture 8.1.1

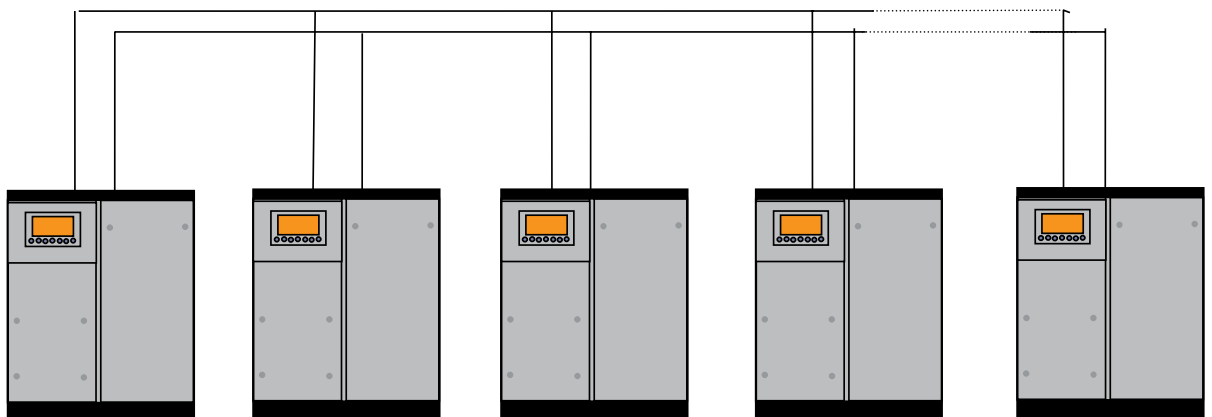

The compressor with COM ADD 0001 is the master, others are slaves. Any one MAM series compressor can be set as a master or slave.

#### 1. Block Control Settings:

##### Set as a master:

Set the COM ADD in USER PARAMETER to 001

According to user requirements, set COM MODE, BLOCK NUMBER, TURN TIME, BLOCK LOAD P, BLOCK UNLD P, BLOCK DELAY, BLOCK MODE. After setup, the controller needs to be powered off and restarted to save the new settings.

##### Set as a slave:

When MAM-6080 controller serves as a slave, it is only necessary to set COM MODE as BLOCK, COM ADD can be set from 2-16 in sequence according to the quantity of compressors. BLOCK STATUS set as SLAVE.

## Block Control and Network Communication (Cont).

### 2. Start, Stop Block mode:

Make sure block cables are connected correctly; the parameter of the compressors in block mode must also be set correctly. Activate the master; the master controls the compressors in the network automatically according to the AIR P readings. When manually stopping the master, block control stops at the same time, thus the master will no longer send commands to the compressors in the network.

## 8.2 Network Communication

MAM-6080 controller supports MODBUS RTU protocol and can serve as a slave when connected with other equipment. It supports 03, 06, 16 MODBUS command systems. Communication baud rate is 9600BPS; 1 start bit, 8 data bits, 1 stop bit and even parity. For MODBUS register address, please see MODBUS communication manual.

## 9. Inverter Control

### 9.1 485 Communication Control

There is one spare port for RS485 to communicate with the inverter. User can start or stop controller through RS485, it transfers the output frequency based on PID calculation to inverter through 485 port. This is how to adjust inverter output frequency and realise constant pressure and temperature. The baud rate is fixed as 9600BPS when RS485 controls inverter. Different inverter data format can be set in INVERTER SET in FACTORY PARAMETER. MOTOR INVERTER is suggested to be set as 0001; FAN INVERTER is suggested to be set as 0002.

In order to be compatible with a different inverter, set the item such as CURR(R) ADD, VOLT(R) ADD, FREQ(R) ADD, POWE(R) ADD, RUN(W) ADD, ERR STATE(R) ADD, FREQ(W), RESET(W) ADD. For different inverters, amplification of current, voltage, frequency, and power is different. Write a formula to every parameter to transfer current, voltage, frequency, and power of inverter to one digit data.

Relative parameter introduction is as below; please take the Schneider 67,71 inverter as example.

## Inverter Control (Cont).

ITEM	DATA SET	EXPLANATION
INVERTER NAME	0ATV61	Set inverter name.
RUN (w) ADD1	2135	Corresponding address 1 of inverter start command.
RUN VALUE	0001	This data is inverter start data (please refer to communication chapter in inverter manual for different inverter).
RUN (w) ADD2	2135	Corresponding address 2 of inverter start command.
RUN VALUE	0001	This data is inverter start data (please refer to communication chapter in inverter manual for different inverter).
STOP (w) ADD	2135	Corresponding address of inverter stop command.
RUN VALUE	0001	This data is inverter start data (please refer to communication chapter in inverter manual for different inverter).
RESET (w) ADD	2135	Corresponding address of inverter reset command.
RUN VALUE	0001	This data is inverter start data (please refer to communication chapter in inverter manual for different inverter).
FREQ (w) ADD	2136	Corresponding register address of inverter running frequency source.
FREQ (r) =	REC*0001÷0001	The REC value is the frequency value to one decimal. Use the formula to transfer to the corresponding value based on a different inverter and send it to the inverter.
STATE (r) ADD	2135	Read inverter run status address.
RUN S =	R AND 0001=0001	Check if inverter has run the formula (please refer to communication chapter in inverter manual).
COM FORM	8N1-N	Set the data format of controller and inverter communication. This setting should be consistent with the inverter communication format.
FREQ (R) ADD	0C82	Read inverter frequency address (refer to inverter manual).
FREQ (r) =	REC*0001÷0001	Calculate inverter frequency formula. Controller will transfer the frequency to one decimal.
VOLT (r) ADD	0C88	Read inverter voltage address.
VOLT (r) =	REC*0001÷0001	Calculate inverter voltage formula. Controller will transfer the voltage to one decimal.
CURR (r) ADD	0C84	Read inverter current address
CURR (r) =	REC*0001÷0001	Calculate inverter current formula. Controller will transfer the current to one decimal.
POWE (r) ADD	0C8B	Read inverter power address.
ERR S =	R AND 0000≠0000	Inverter reports error in the formula or not.
EMERGENCY ADD	2135	Corresponding address of inverter emergency stop command.
RUN VALUE	0001	This data is inverter free stop data (please refer to communication chapter in inverter manual for different inverter).

Firstly, the controller sends 0 to corresponding register of "STATE(R) ADD" to the inverter. After delay, it sends 1 to corresponding register of "RUN1(W) ADD".

After another delay, it reads "RUN S" register, and calculates if the inverter is running based on the set formula.

Calculation of the output frequency is based on the comparison of pressure detected and pressure set. This value is sent to corresponding address of "FREQ(R) ADD" through formula operation.

### Schneider inverter parameter settings:

```

1. CON |AD2-
      |AD1-|ADD: 1
      |EBr :96
      |EFO :8N1
      |EEO :15

CTL-  |Fr1: ndb
      |rln
      |PST
      |CHCF: IO

Flt-  |CD1: ndb
      |PTC-
      |rST- |rSF: C107
    
```

## 10. Schematic Wiring Diagram

### 10.1 SR Fixed Speed Single Stage Models SR-75H up to SR-175H with MAM-6080 Controller

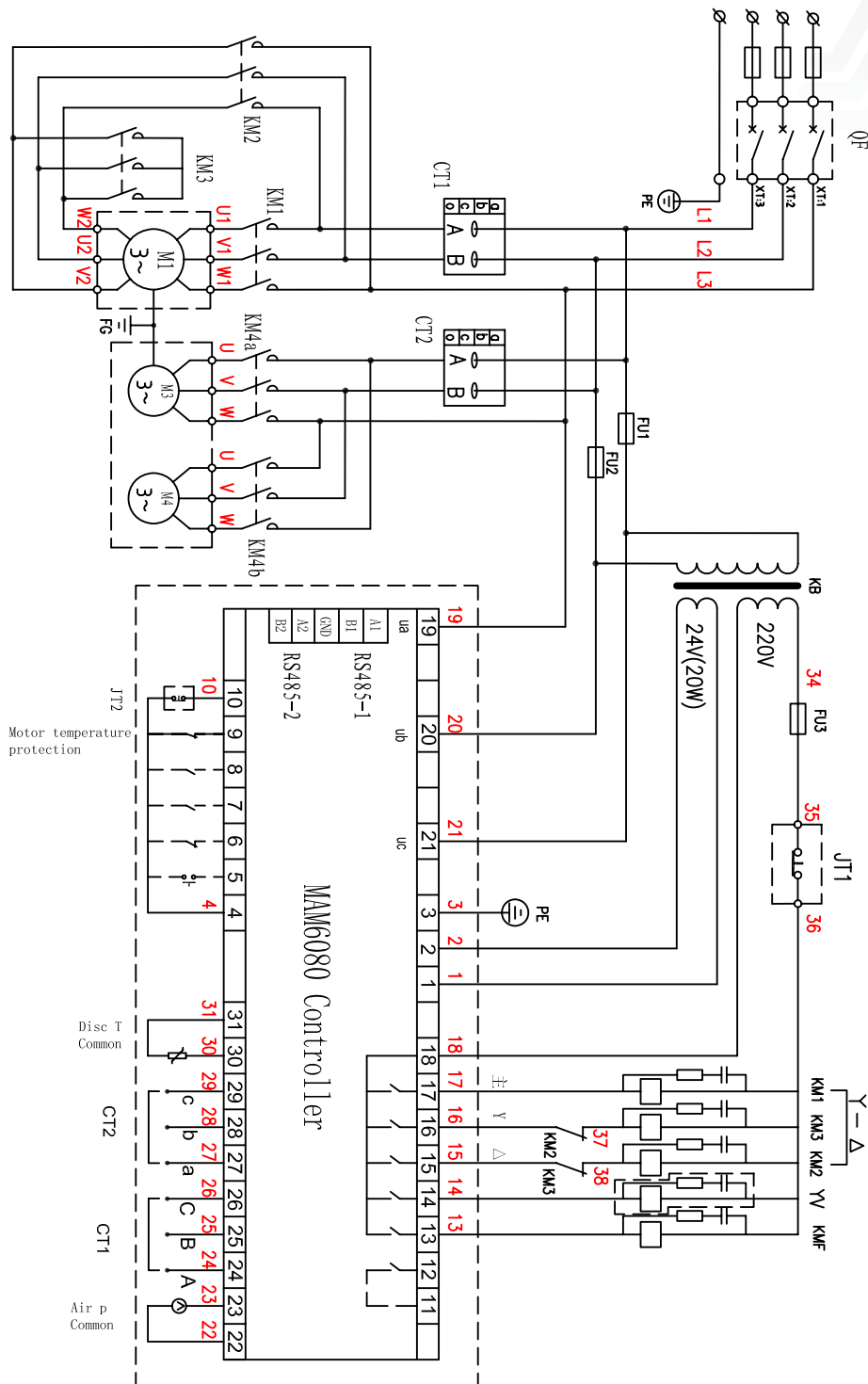



## Schematic Wiring Diagram (Cont.)

### 10.2 SR Variable Speed Models Single Stage Models SR-10VSD up to SR-175HVSD with MAM-6080 Controller

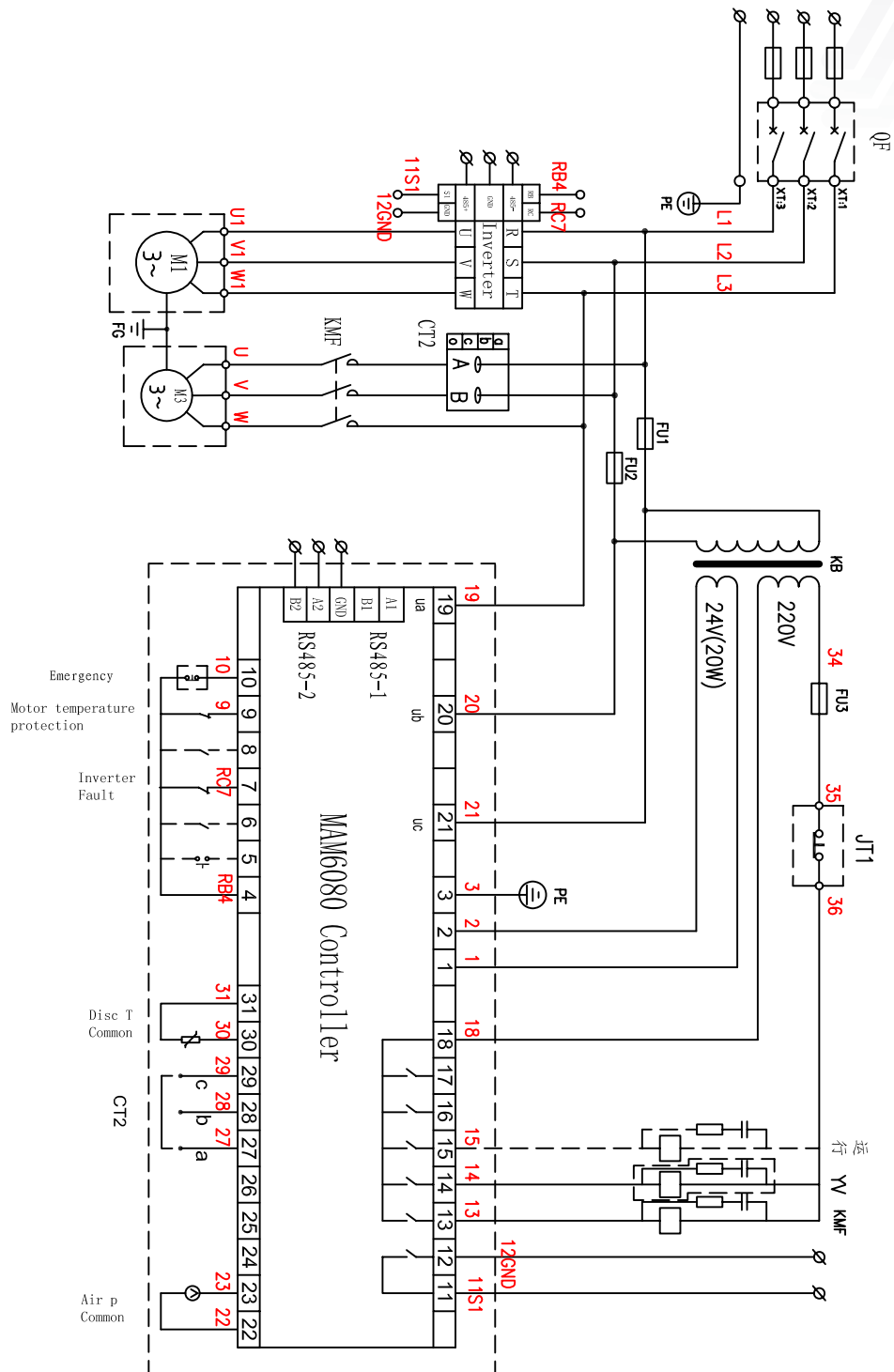

## Schematic Wiring Diagram (Cont.)

### 10.3 SR Variable Speed Two-Stage with MAM-6090 Controller

*Reliable Machinery from the Experts.*



*Reliable Machinery from the Experts.*



## 11. Appendix - Output Mode Options

4 optional control modes have been added to 6070, 6080 and 6090 models. The user can choose to activate the modes of function.

**The introduction is shown below:**

Turn on "Output Option" in Motor VSD Parameter. The menu selection interface will increase "Output Option".



Click "Output Option" and enter the interface as shown below. Users can choose the proper speed adjustment mode according to their needs.

*When the "Mode" is closed here, user must open "Output Option" in Motor VSD Parameter*

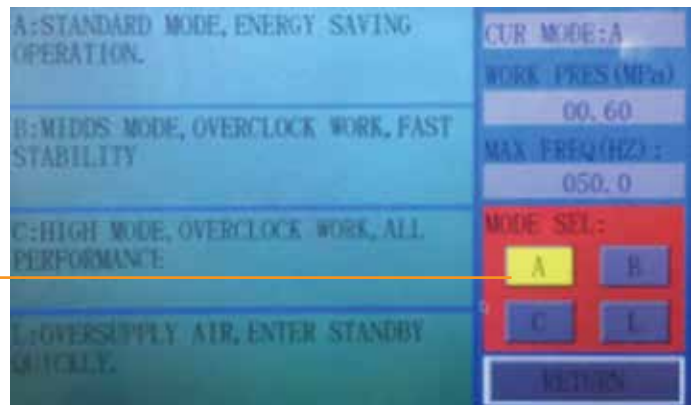

- **Mode A:**  
In this mode, the motor is sped up to motor the rated frequency at the inverters maximum acceleration after start. After running for some time, and pressure is close to the constant set-pressure, the PLC will increase/decrease frequency intelligently according to the pressures rate of increase in relation to the set pressure. The pressure will stabilize to constant pressure level in this mode.
- **Mode B:**  
(Overclocking Operation): In this mode, the motor is sped up to the corresponding frequency value according to constant power pressure point set by the user after start. After running for some time, set-pressure is close to constant pressure; the PLC will intelligently increase/decrease frequency according to pressure increase/decrease rate and stabilize pressure to a constant pressure level. (New mode 1).
- **Mode C:**  
(Overclocking and High-speed Operation): In this mode, the motor is sped up to the corresponding frequency value according to constant power pressure point set by the user after start. It creates the quickest air output. This mode will make full use of the air compressor output capability. (New mode 2).
- **Mode L:**  
This mode is based on Mode A to reduce the running time in low frequency and to achieve the best energy saving mode (New mode 3).